

Syringe-based Nanoparticle System

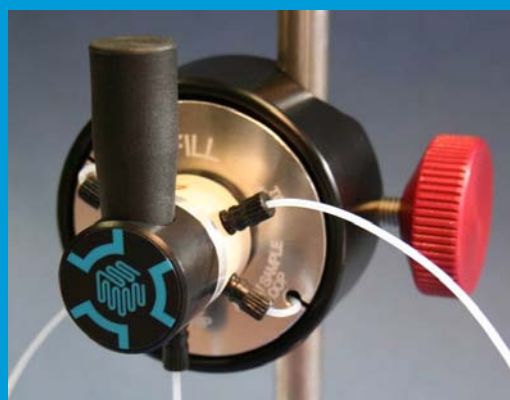
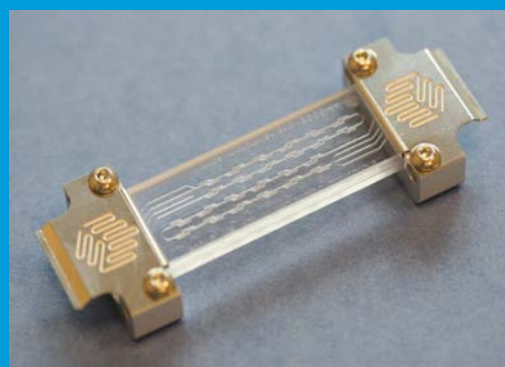

product datasheet	page
Description	2
Nanoparticle Synthesis	3
Main benefits	4
Applications	4
System Components	5
Specification	6
Syringe-based Nanoparticle Starter Kit	7
Accessories	8
Custom Options	8

Description

The Syringe-based Nanoparticle System provides a complete solution for the generation of polymeric, metal and semi-conductor nanoparticles from 1nm to 100nm in diameter. Operating over a wide flow range, from 0.1 μ l/min to 10ml/min, this chemically resistant system is ideal for biomedical, chemical and optical applications.

Featuring Dolomite's micromixer technology to enable the rapid and effective mixing of 2 reagents, the system uses extra smooth pumps to deliver the reagents into the mixing region. This ensures that nanoprecipitation occurs consistently throughout the sample, providing tight particle size distributions.

Reagent volumes from 25 μ l to 10ml can be introduced into the flow path by using the Sample Injection Valve which minimizes reagent consumption and allows users to optimize the flow set-up before initiating the reaction.

Reaction times and temperatures can be carefully controlled using this microfluidic system to obtain improved results compared with macro-scale alternatives. The small channel sizes in the micromixer and thermal control module ensure that constant temperatures are maintained throughout the experiment.

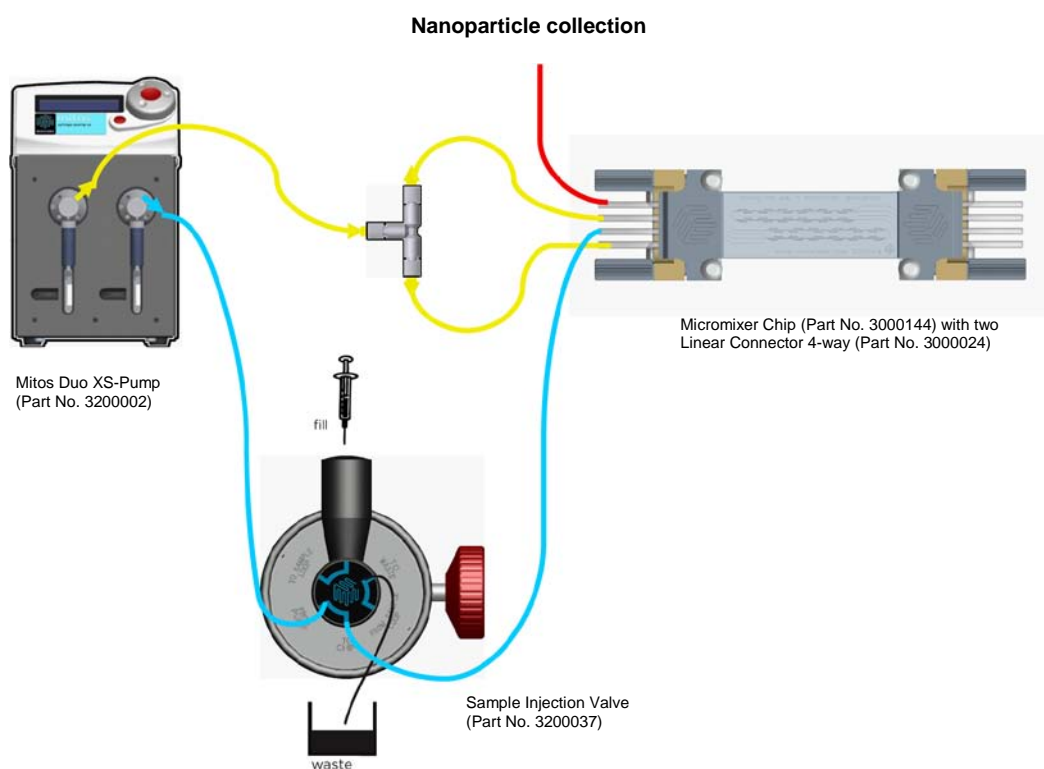

Syringe-based Nanoparticle System

Nanoparticle Synthesis

Microfluidics technology is ideal for nanoparticle synthesis. Reducing reagent consumption, it allows tighter particle size distributions, improved control over reaction times and temperatures, as well as better mixing efficiency.

The Syringe-based Nanoparticle System features Dolomite's micromixer technology to enable the rapid and effective mixing of up to 2 reagents as illustrated in the diagram below:

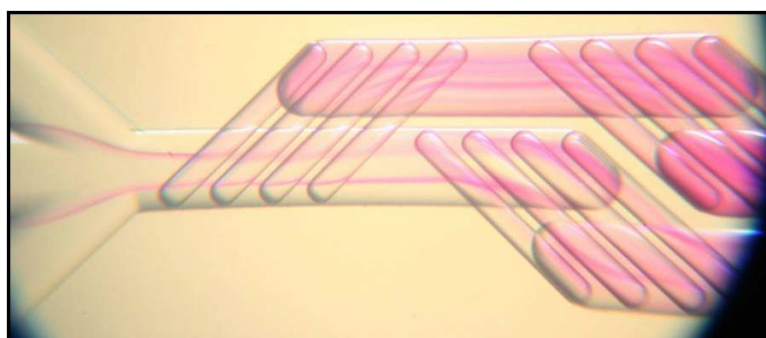
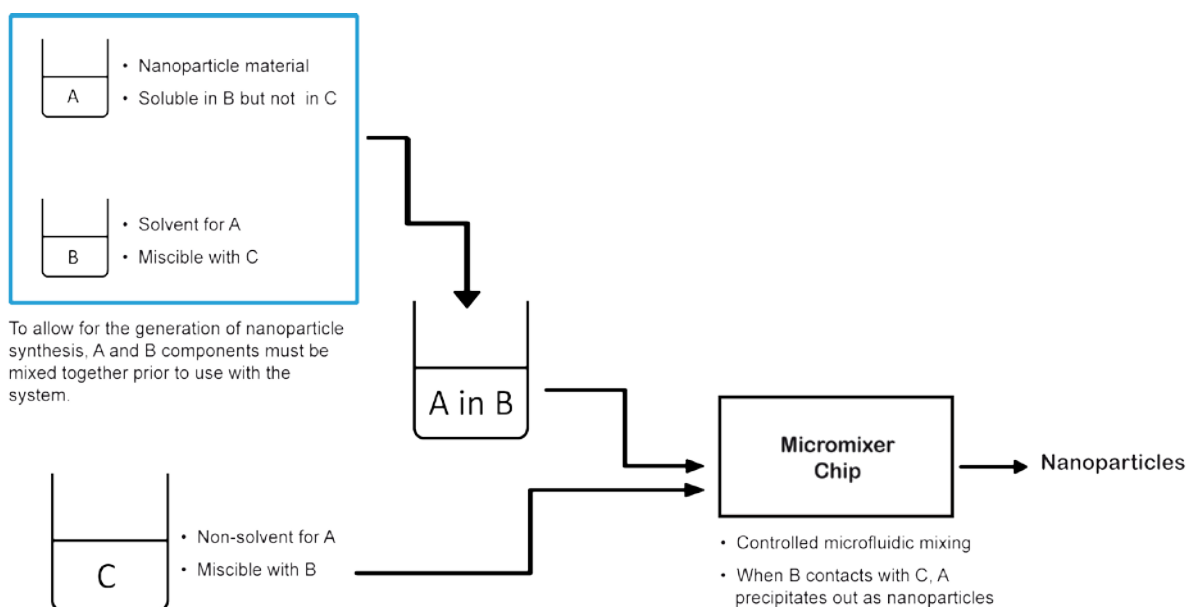

Micromixer Chip (Part No. 3000144)

Main benefits

- Tighter particle size distributions
 - Reduced reagent consumption
 - Wide pressure range 0 - 6bar
 - Improved control over reaction times and temperatures
 - Better mixing efficiency
- Excellent chemical resistance

Applications

The Syringe-based Nanoparticle System allows user to generate polymeric, metal and semi-conductor nanoparticles benefiting a wide range of applications including:

- Drug delivery
- Biomolecular sensing
- Cellular imaging
- Targeted heating in biomedical applications
- Fibre-optics
- Catalysts

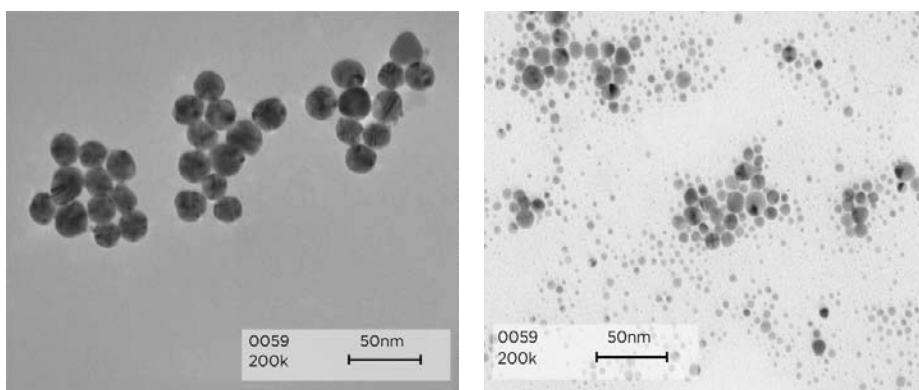

Microscopic images of nanoparticles

System Components

The Syringe-based Nanoparticle System is built around Dolomite's industry leading microfluidic pumps, connectors and chips and consists of:

- 1 x Mitos Duo XS-Pump (Part No. 3200057)
2 x Syringe for Mitos Duo XS-Pump, 1ml (Part No. 3000252)
2 x Valve for Mitos Duo XS-Pump, 4-port (Part No. 3000246)

The Mitos Duo XS-Pump is ideal for nanoparticle synthesis due to simplicity of use and extra smooth syringe drive technology. The pump comprises of two independent syringes, with two rotary valves, enabling fast automatic refill from up to 3 different sources, as well as an independent control of each liquid channel.

- 1 x Micromixer Chip (Part No. 3000144)
A glass microfluidic device featuring two independent channels, designed for rapid mixing of two or three fluid streams. The chip is supplied with two headers that allow quick and reliable connection to the Linear Connector 4-way minimizing downtime.
- 2 x Linear Connector 4-way (Part No. 3000024)
Providing fast, reliable and efficient connection between the Micromixer Chip and 1.6mm O.D. tubing.
- 1 x Sample Injection Valve (Part No. 3200037)
Allowing small liquid samples to be pumped into microfluidic systems without the sample passing through a pump.
- 1 x Hotplate Adaptor (Part No. 3000207)
With the ability to hold the Micromixer Chip in position, the Hotplate Adaptor allows users to control the temperature of microfluidic chips and works in conjunction with a range of hotplates.

- Syringe-based Nanoparticle Starter Kit (Part No. 3200231)
Containing a selection of tubing and fittings.







All components of the Syringe-based Nanoparticle System are quick and easy to connect and disconnect, ensuring that reliable and accurate data is obtained within a short time-span.

Specifications

Technical information	Syringe-based Nanoparticle System
Number of input reagents	2
Internal channel cross section of Micromixer	125µm x 350µm and 50µm x 125µm (depth x width)
Internal volume of Micromixer	8µl
Internal volume of a mixing stage	0.35µl
Back pressure with 100µl/min flow (water)	0.1bar
Connection tubing material	PTFE, FEP
Material of Micromixer Chip	Glass
Flow rate range	0.1µl/min - 10ml/min
Operating pressure range	0 - 6bar (0 - 90PSI)
Sample loop volume range	25µl – 10ml
Pump type	Extra smooth syringe pump

Syringe-based Nanoparticle Starter Kit

This Starter Kit (Part No. 3200231) contains all the required tubing, fittings and accessories for carrying out experimentation with the Syringe-based Nanoparticle System.

Part No.	Component	Image
3000397	1 x T- Connector ETFE 0.5mm I.D. for 1.6mm O.D. tube	
3200063	1 x FEP Tubing, 1/16" x 0.25mm, 10 metres Tubing which can be used to connect connectors to the Mitos Duo XS-Pump	
3000477	1 x End fittings and ferrules for 1.6mm tubing This pack contains various end fittings and ferrules which can be used to connect the fluid tubes to the Mitos Duo XS-Pump	
3800073	1 x Precision Tube Cutter PTFE Tube Cutter for tubing of 2mm outside diameter and below	
3000311	1 x Female to Female Luer Lock For making connections between head fittings and syringes	
3000056	1 x Plug FEP (Pack of 10) Enabling users to block flow out of a port on a chip or connector	

Accessories

Dolomite offers a broad range of accessories to be used with the Syringe-based Nanoparticle System:

- Syringe for Mitos Duo XS-Pump, 50µl (Part No. 3000248)
- Syringe for Mitos Duo XS-Pump, 100µl (Part No. 3000249)
- Syringe for Mitos Duo XS-Pump, 250µl (Part No. 3000250)
- Syringe for Mitos Duo XS-Pump, 500µl (Part No. 3000251)
- Syringe for Mitos Duo XS-Pump, 2.5ml (Part No. 3000253)
- Syringe for Mitos Duo XS-Pump, 5ml (Part No. 3000254)
- Valve for Mitos Duo XS-Pump, 2-port (Part No. 3000244)
- Valve for Mitos Duo XS-Pump, 3-port (Part No. 3000245)
- Valve for Mitos Duo XS-Pump, 6-port (Part No. 3000247)

Custom Options

Dolomite works with customers around the world to develop a variety of versatile, complex and cutting edge custom devices.

Our microfluidic chips can be customized in a number of ways, including different etch depths and widths as well as a wide range of surface coatings. Alternative nanoparticle synthesis chip designs can be generated which utilise mechanisms such as hydrodynamic flow focusing or 2-phase droplet flow. Please contact Dolomite to discuss your project requirements with one of our design engineers!



The Dolomite Centre Ltd.

Unit 1, Anglian Business Park, Royston,
Hertfordshire, SG8 5TW, United Kingdom

T: +44 (0)1763 242491

F: +44 (0)1763 246125

E: info@dolomite-microfluidics.com

W: www.dolomite-microfluidics.com

Dolomite Microfluidics

29 Albion Place
Charlestown, MA 02129

F: 617 848 1211

F: 617 500 0136

E: salesus@dolomite-microfluidics.com

W: www.dolomite-microfluidics.com