

Droplet Junction Chip characterisation

Performance of the Droplet Junction Chip for generating water droplets in a hexadecane carrier stream

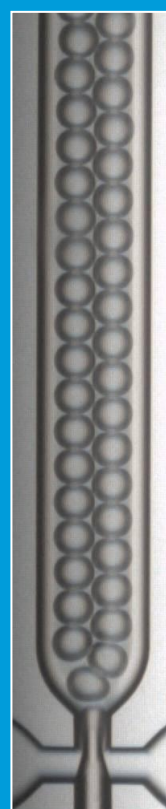

Application Note	Page
About Droplet Generation	2
Droplet Generation Test Set-up	2
Results	3
Analysis	4
Flow Rate Calculation	4
Droplet Volume	5
Conclusion	5

Results









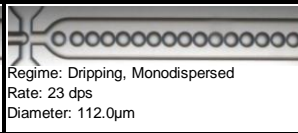
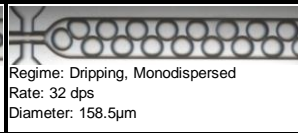

		Water Pressure /mbar					
		30	100	300	1000	3000	6000
Oil Pressure /mbar	30	 Regime: Dripping, Monodispersed Rate: 11 dps Diameter: 90.8µm	 Regime: Dripping, Monodispersed Rate: 23 dps Diameter: 112.0µm	 Regime: Dripping, Monodispersed Rate: 32 dps Diameter: 158.5µm	 Regime: Dripping, Chaotic Rate: Diameter:		CHAOTIC
	100	 Regime: Dripping, Monodispersed Rate: 56 dps Diameter: 46.5µm	 Regime: Dripping, Monodispersed Rate: 70 dps Diameter: 73.9µm	 Regime: Dripping, Monodispersed Rate: 140 dps Diameter: 86.6µm	 Regime: Dripping, Monodispersed Rate: 250 dps Diameter: 109.9µm	 Regime: Dripping, Chaotic Rate: Diameter:	
	300		 Regime: Dripping, Monodispersed Rate: 234 dps Diameter: 44.4µm	 Regime: Dripping, Monodispersed Rate: 404 dps Diameter: 59.2µm	 Regime: Dripping, Monodispersed Rate: 752.6 Diameter: 73.9µm	 Regime: Dripping, Monodispersed Rate: 1549 dps Diameter: 84.5µm	 Regime: Dripping, Monodispersed Rate: 1654 dps Diameter: 105.6µm
	1000			 Regime: Dripping, Monodispersed Rate: 2787 dps Diameter: 27.5µm	 Regime: Dripping, Monodispersed Rate: 4305 dps Diameter: 40.6µm	 Regime: Dripping, Monodispersed Rate: 7924 dps Diameter: 48.6µm	 Regime: Jetting, Monodispersed Rate: 1362 dps Diameter: 114.1µm
	3000	BACKFLOW			 Regime: Jetting, Monodispersed Rate: 42403 dps Diameter: 16.9µm	 Regime: Jetting, Monodispersed Rate: 5040 dps Diameter: 54.9µm	 Regime: Jetting, No Droplets Rate: Diameter:
	6000					 Regime: Jetting, No Droplets Rate: Diameter:	 Regime: Jetting, No Droplets Rate: Diameter:

Chart showing flow regimes at varied pressures

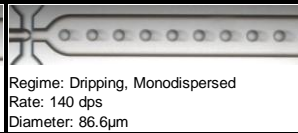
Analysis

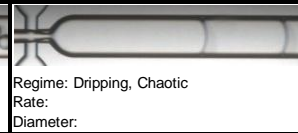
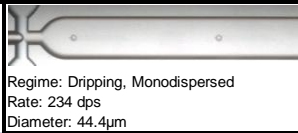
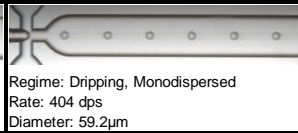
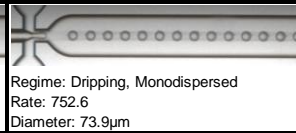
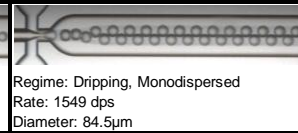
The images captured during the experiment show the flow regimes at various pressure combinations. Four different flow regimes were observed:

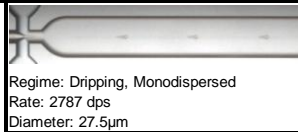
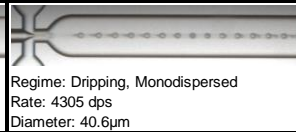
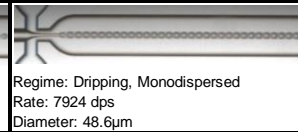
- **Dripping regime** – This occurs at lower flow rates and results in monodisperse droplet formation.
- **Jetting regime** – This occurs at higher flow rates and can result in monodispersed droplets but can also give polydispersed droplets. At very high flow rates annular flow can occur with no droplet formation.
- **Chaotic** – This occurs when the water flow rate is significantly higher than the oil flow rate. Droplet size is generally polydisperse.
- **Backflow** – This is characterised by the oil stream flowing back into the water feed channel. This occurs when the backpressure generated in the output channel and output pipe is greater than the pressure set on the water Mitos P-Pump. To avoid backflow the resistance of the flow resistor on the water input stream should be increased.

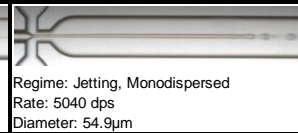
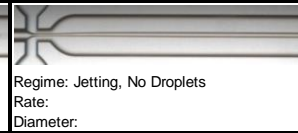
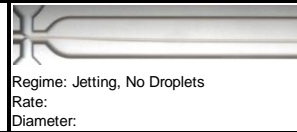
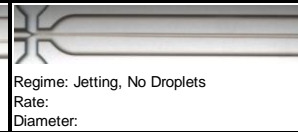
Flow Rate Calculation

The fluidic layout can normally be represented schematically as shown in the diagram below where W is the water droplet stream and O is the oil carrier fluid. This assumes that the flow resistance after the droplet junction, R_j , is low relative to the flow resistance of the two input streams R_w and R_o .

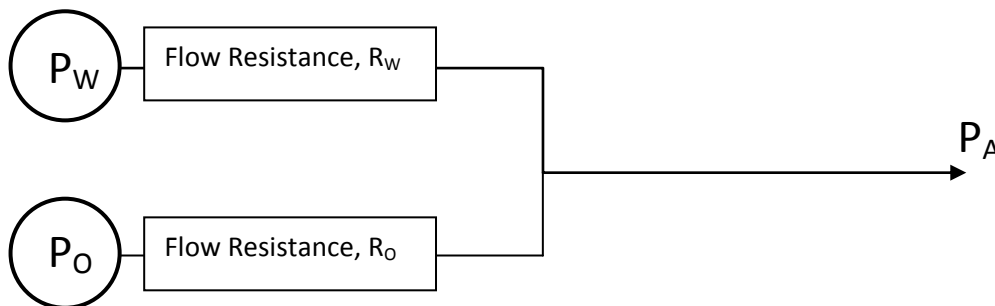

The flow rate in each feed stream can be estimated using the following two equations:

$$Q_w = \frac{P_w}{R_w \times \mu_w}, \quad Q_o = \frac{P_o}{R_o \times \mu_o}$$

Q = Flow rate
P = Pressure in P-Pump
 μ = viscosity
R = flow resistance

The Microfluidic Calculator on www.dolomite-microfluidics.com can be used to estimate flow rates using the equation shown above.

If R_j is high relative to R_x and R_y then it is necessary to first calculate the pressure at the droplet junction to get an accurate estimate of all the flow rates in the system.

The schematic below shows R_J and the equation can be used to estimate the pressure at the junction, P_J . The equation assumes that the viscosity of the output stream is equal to the viscosity of the carrier fluid. This is generally a good approximation if the carrier flow rate is higher than the droplet flow rate.

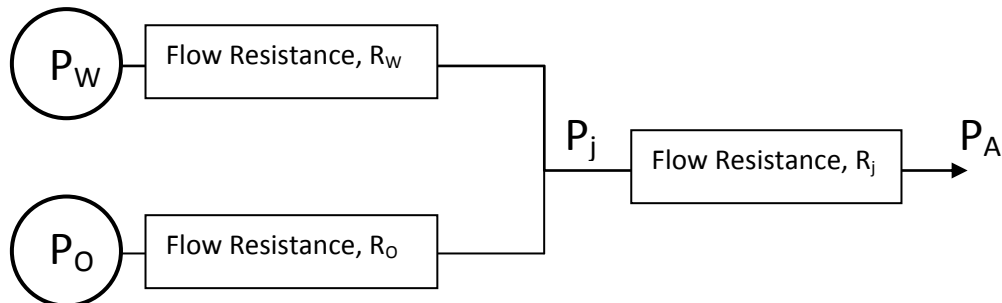

$$P_J = \frac{P_W \cdot W + P_O \cdot O}{J + W + O}$$

Where:

$$W = \frac{1}{R_W \times \mu_W}, \quad O = \frac{1}{R_O \times \mu_O}, \quad J = \frac{1}{R_J \times \mu_O}$$

R_W = flow resistance of the water input channel

R_O = flow resistance of the oil input channel

R_J = flow resistance of the channel after the junction

μ_W = viscosity of water

μ_O = viscosity of oil

P_J = pressure at junction

P_W = MitoS P-Pump pressure on water

P_O = MitoS P-Pump pressure on oil

The flow rates can then be calculated as follows:

$$Q_W = (P_W - P_J) \cdot W, \quad Q_O = (P_O - P_J) \cdot O$$

These equations are useful for predicting backflow scenarios for a MitoS P-Pump set-up.

Droplet Volume Calculations

Droplet volume is normally calculated assuming a spherical droplet shape. If the diameter of the droplet observed in a microchannel is greater than the channel depth (100 μ m in this instance) then the droplet shape will be a squashed cylinder, as shown below. The equation for calculating the volume of this cylinder is shown below.

Equations Used

For Spherical Droplet

Volume of Droplet

Droplet $D <$ Channel Depth

$$V = \frac{4}{3}\pi r^3$$

For Squashed Cylinder

Volume of Cylinder

Droplet $D >$ Channel Depth

$$V_c = \left(\frac{r - \frac{d}{2}}{2} \right)^2 \times d \times \pi$$

Distance to Centroid

$$c = r - \frac{d}{2} + \frac{4 \times r}{3 \times \pi}$$

Area of Semicircle

$$A_s = \frac{\pi \times \frac{d^2}{4}}{2}$$

Volume of Semicircular Ring $V_s = A_s \times \pi \times c \times 2$

Total Droplet Volume

$$V_t = V_c + V_s$$

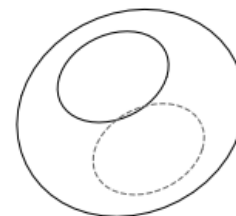
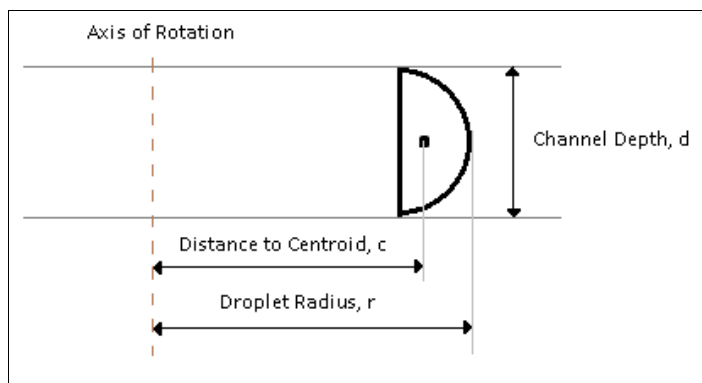

Side View of Droplet

Conclusion

The flow regime chart illustrates that there is a region where monodisperse droplet generation occurs. The pressure ratio can be used to adjust droplet size. When the difference in the flow rates of the two phases is very large, the flow may become chaotic with no droplets formed. With increased pressures droplets can be generated at over 10,000 droplets per second.



The Dolomite Centre Ltd.

Unit 1, Anglian Business Park, Royston,
Hertfordshire, SG8 5TW, United Kingdom

T: +44 (0)1763 242491

F: +44 (0)1763 246125

E: info@dolomite-microfluidics.com

W: www.dolomite-microfluidics.com

Dolomite Microfluidics

29 Albion Place
Charlestown, MA 02129

F: 617 848 1211

F: 617 500 0136

E: salesus@dolomite-microfluidics.com

W: www.dolomite-microfluidics.com